

- ISO 5211 DIRECT MOUNTING PAD
- BLOW-OUT PROOF STEM
- T-CLAMP END
- WORKING PRESSURE(CWP) :
DN8~DN50 1000psi
DN65~DN80 800psi
- TEMPERATURE RANGE: -20 to 180°C
- LOCKING DEVICE

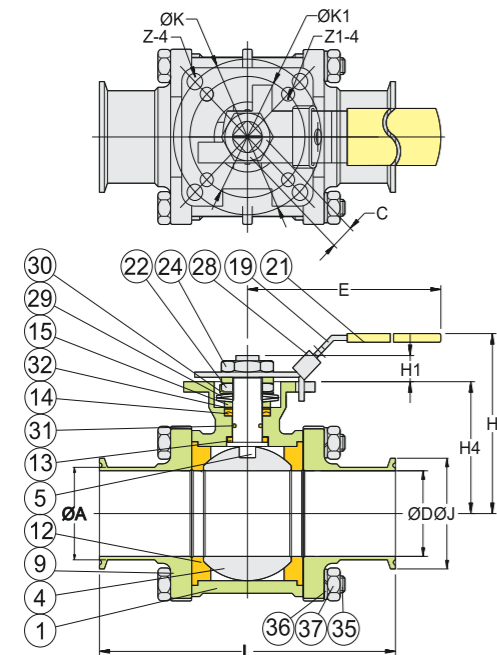

MATERIALS LIST

NO.	PART NAME	MATERIAL
1	BODY	ASTM A351 Gr.CF8M
4	BALL	SS316
5	STEM	SS316
9	END CAP	ASTM A351 Gr.CF8M
12	SEAT	RTFE.
13	THRUST WASHER	PTFE.
14	STEM PACKING	RTFE.
15	GLAND BUSH	SS304
19	HANDLE	SS304
21	HANDLE COVER	VINYL GRIP
22	STEM NUT	SS304
24	HANDLE NUT	SS304
28	LOCKING PAD	SS304
29	BELLEVILLE WASHER	SS304-CSP
30	TAB WASHER	SS304
31	O-RING	VITON
32	PACKING FOLLWER	PTFE.+25%G.F.
35	BODY BOLT	SS304
36	BOLT WASHER	SS304
37	BOLT NUT	SS304

DIMENSIONS

SIZE	A	L	E	H	H1	H4	C	K	K1	Z-4	Z1-4	D	J	
DN15	1/2"	12.70	70.9	112.0	73.0	8.5	37.0	9.0	50.0	36.0	7.0	6.0	22.5	22.5
DN20	3/4"	19.05	80.8	112.0	80.8	8.5	45.0	9.0	50.0	36.0	7.0	6.0	27.5	27.5
DN25	1"	25.50	90.5	136.0	90.5	11.4	53.5	9.0	50.0	36.0	7.0	6.0	34.0	34.0
DN40	1-1/2"	38.20	115.3	197.9	115.3	14.0	74.8	14.0	70.0	50.0	9.0	7.0	52.0	52.0
DN50	2"	50.80	124.0	197.9	124.0	13.7	83.5	14.0	70.0	50.0	9.0	7.0	63.5	63.5
DN65	2-1/2"	63.60	155.0	267.0	155.0	18.0	108.8	17.0	102.0	70.0	11.0	9.0	85.5	85.5
DN80	3"	76.30	208.5	267.0	208.5	18.0	118.3	17.0	102.0	70.0	11.0	9.0	102.0	102.0
DN100	4"	101.6	216.7	322.0	216.7	18.0	153.8	17.0	102.0	70.0	11.0	9.0	128.5	128.5

- BLOW-OUT PROOF STEM
- WORKING PRESSURE(CWP) :
DN8~DN50 1000psi
DN65~DN100 800psi
- TEMPERATURE RANGE: -20 to 180°C
- FULLED CAVITY PTFE SEAT
- LOCKING DEVIC

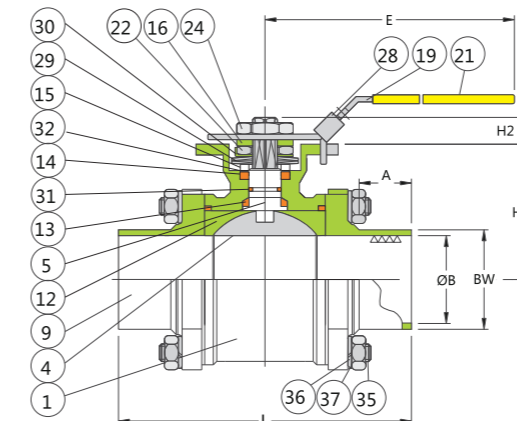
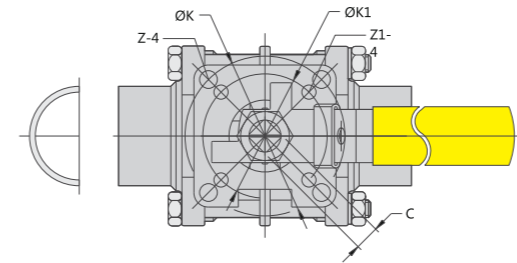

MATERIALS LIST

NO.	PART NAME	MATERIAL
1	BODY	ASTM A351 Gr.CF8M
4	BALL	ASTM A351 Gr.CF8M
5	STEM	SS316
9	END CAP	ASTM A351 Gr.CF8M
12	SEAT	PTFE/TFM1600.
13	THRUST WASHER	PTFE.
14	STEM PACKING	PTFE.
15	GLAND BUSH	SS304
16	HANDLE GLAND	SS304
19	HANDLE	SS304
21	HANDLE COVER	VINYL GRIP
22	STEM NUT	SS304
24	HANDLE NUT	SS304
28	LOCKING PAD	SS304(OPTION)
29	BELLEVILLE WASHER	SS304-CSP
30	TAB WASHER	SS304
31	O-RING	VITON
32	PACKING FOLLWER	RTFE.
35	BODY BOLT	SS304
36	BOLT WASHER	SS304
37	BOLT NUT	SS304

DIMENSIONS

SIZE	A	L	E	H	H1	H2	C	ØK	ØK1	Z-4	Z1-4	BW	ØB	
DN15	1/2"	20.0	82.5	112.0	73.0	37.0	8.5	9.0	50.0	36.0	7.0	6.0	12.7	10.2
DN20	3/4"	20.0	87.5	112.0	80.8	45.0	8.5	9.0	50.0	36.0	7.0	6.0	19.1	15.8
DN25	1"	20.0	96.0	136.0	90.5	53.5	9.5	9.0	50.0	36.0	7.0	6.0	25.4	22.1
DN40	1-1/2"	20.0	118.0	197.9	115.3	74.8	14.0	14.0	70.0	50.0	9.0	7.0	38.2	34.8
DN50	2"	20.0	131.7	197.9	124.0	83.5	13.7	14.0	70.0	50.0	9.0	7.0	50.8	47.5
DN65	2-1/2"	20.0	158.5	267.0	155.0	108.8	18.0	17.0	102.0	70.0	11.0	9.0	63.4	60.2
DN80	3"	20.0	178.8	267.0	208.5	118.3	18.0	17.0	102.0	70.0	11.0	9.0	76.2	72.9
DN100	4"	20.0	210.5	322.0	216.7	153.8	18.0	17.0	102.0	70.0	11.0	9.0	101.6	97.4